

STRAIGHT SQUARE FLANGE PLUG SOLDER TYPE

R125.256.009

CABLE .085

Series : SMA

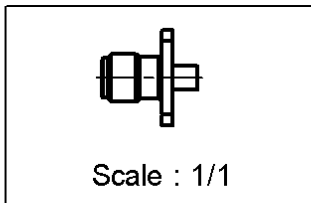
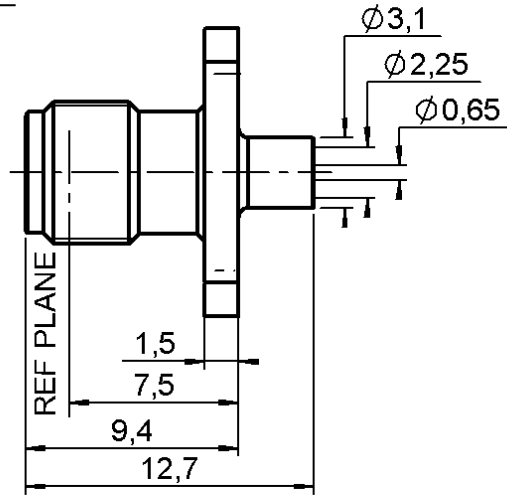
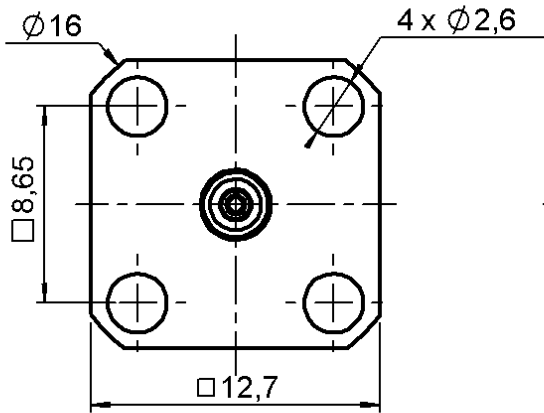

PANEL CUT OUT

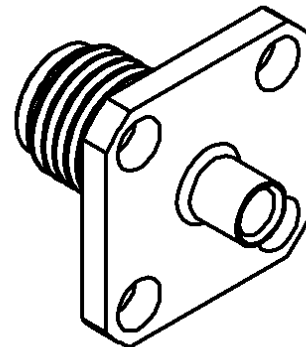
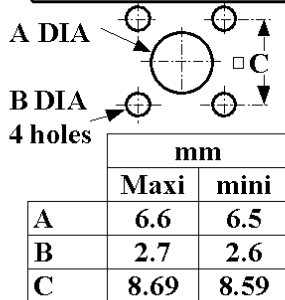

All dimensions are in mm.



COMPONENTS	MATERIALS	PLATINGS (µm)
BODY	BERYLLIUM COPPER	GOLD 1.3 OVER COPPER 2
CENTER CONTACT	BERYLLIUM COPPER	GOLD 2.54 OVER COPPER 2.54
OUTER CONTACT	-	-
INSULATOR	PTFE	-
GASKET	-	-
OTHERS PARTS	-	-
-	-	-
-	-	-

Issue : 0323 C

In the effort to improve our products, we reserve the right to make changes judged to be necessary.



STRAIGHT SQUARE FLANGE PLUG SOLDER TYPE

R125.256.009

CABLE .085

Series : SMA

PACKAGING

Standard	Unit	Other
1	-	Contact us

SPECIFICATION

CABLE ASSEMBLY

ELECTRICAL CHARACTERISTICS

Stripping	a	b	c	d	e	f
mm	3.17	0.00	0.00	0.00	0.00	0.00

Impedance		50	Ω
Frequency		0-18	GHz
VSWR	1.07 +	0.008	x F(GHz) Maxi
Insertion loss		0.03	\sqrt{F} (GHz) dB Maxi
RF leakage	- (90	- F(GHz)) dB Maxi
Voltage rating		335	Veff Maxi
Dielectric withstanding voltage		750	Veff mini
Insulation resistance		5000	M Ω mini

Assembly instruction : **Solder 01**

Recommended cable(s)
KS 1
RG 405

Characteristics indicated on this data sheet are those that can be achieved with the highest performance cable. Intrinsic limitations of the cable may diminish the performance of the assembly

Cable retention

- pull off **130** N mini
- torque **NA** N.cm

MECHANICAL CHARACTERISTICS

TOOLING

Center contact retention			
Axial force – Mating end	NA	N	N mini
Axial force – Opposite end	NA	N	N mini
Torque	NA	N.cm	mini

Part Number	Description	Hexagon
R282.051.000	STRIPPING TOOL	
R282.063.000	POINTER GAUGE	
R282.740.000	SOLDERING MOUNTING	
R282.744.220	SOLDERING POSITIONER (CENTER CONTACT)	
R282.862.060	CONTROL GAUGE	
R282.730.043	INSULATOR MOUNTING TOOL	
R282.915.010	DIELECTRIC RECESS TOOL	
R282.914.010	DIELETRIC RECESS GAUGE	
R282.744.010	SOLDERING POSITIONER (BODY)	
R282.120.010	SMA TOOLBOX	

Recommended torque			
Mating	NA	N.cm	
Panel nut	NA	N.cm	
Clamp nut	NA	N.cm	
A/F clamp nut	0.000	mm	

Mating life	500	Cycles mini
Weight	4.000	g

ENVIRONMENTAL

Operating temperature	-65/+105	$^{\circ}$ C
Hermetic seal	NA	Atm.cm3/s
Panel leakage	NA	

OTHERS CHARACTERISTICS

Issue : 0323 C

In the effort to improve our products, we reserve the right to make changes judged to be necessary.

